

CONNECTING A OMRON CPM-2A PLC TO YOUR NETWORK

Abstract

This document explains how to connect a Omron CPM-2A PLC Series to an Ethernet network through our family of Serial-to-Ethernet converters, SSE232. Read this Technical Note if you need to achieve remote connectivity between a PLC and a networked computer, using CX Programmer V2 from Omron®.

Used Hardware

- Omron® CPM-2A PLC .
- Adapting module CIF01.
- Communication cable, as shown below.
- Serial-to-Ethernet converter, Exemys SSE232-1C43-ST

Used Software

- Operating system: Windows® 98
- Exemys Device Locator: software used to find any Exemys device attached to your LAN
- Programming software: CX Programmer V2.0
- Serial-to-Ethernet software redirector, Serial IP V2.4 or higher.

Procedure

Connect your computer, your Exemys converter, the adapter and your PLC as follows:

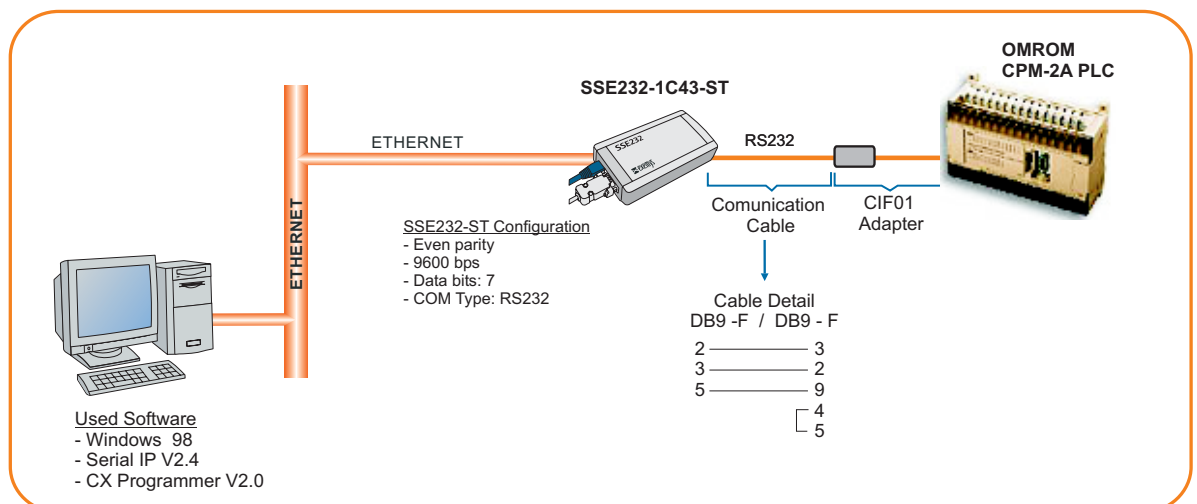

Configure your device with Exemys Device Locator

- Assign a valid IP address, Netmask and Gateway to your SSE232-ST.

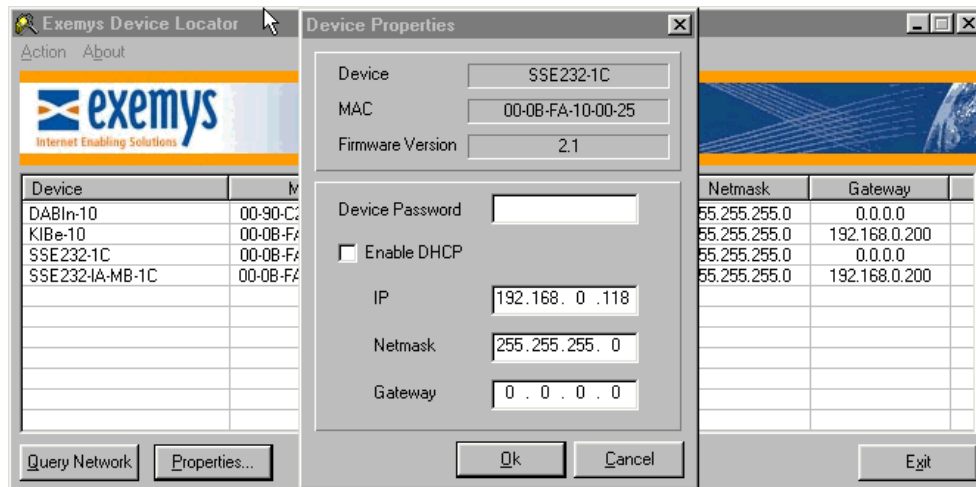

Configure the serial port in your SSE232-ST

- Baud rate: 9600 bps
- Parity: even
- Data Bits: 8
- Com Typo: RS232

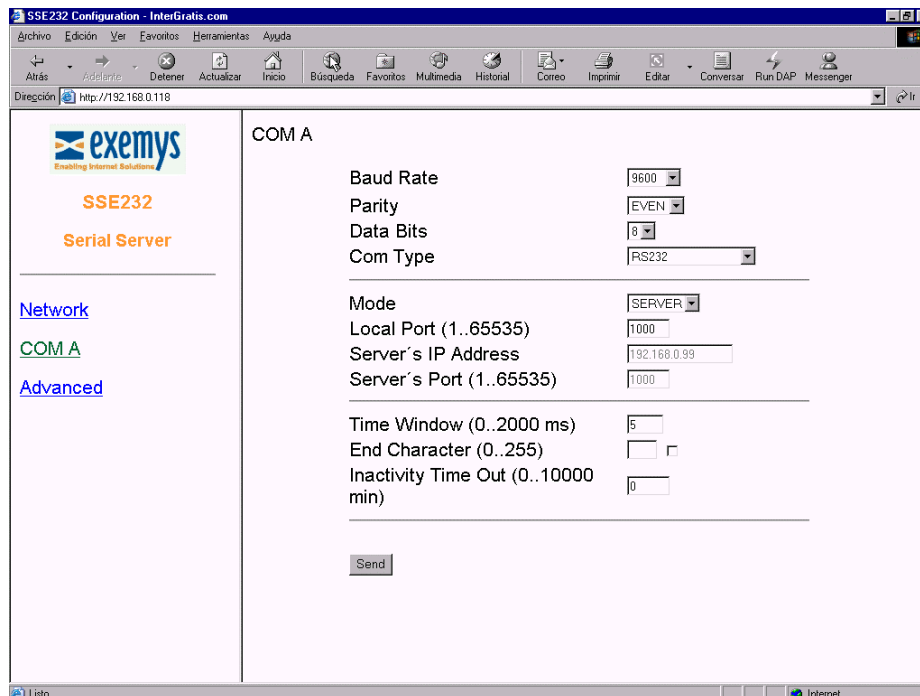

Configure Serial IP

- Install and run Serial IP. Add a virtual serial port. Configure the virtual port to route data into your local IP and TCP port 1000. Select *Raw TCP Connection* and enable all options in the *Com Port Options* menu.

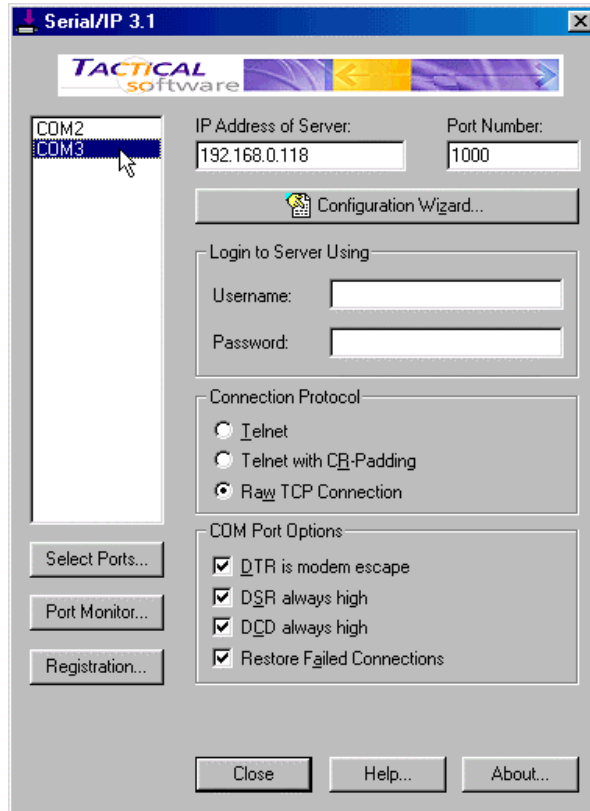

Configure CX Programmer V2.0

- Select the virtual serial port in the application (the one you configured using Serial IP).
- Configure the baudrate, 9.600 bps
- Configure parity even, 8 data bits

Following the steps described above, you will be able to use your PLC just as if it was connected directly to your PC.

For technical support please contact:
support@exemys.com

For sales please contact:
sales@exemys.com

www.exemys.com



Exemys products are in constant evolution to satisfy our customers needs. For that reason, the specifications and capabilities are subject to change without prior notice. Updated information can be found at www.exemys.com
Copyright © Exemys, 2003. All Rights Reserved. R3.01
The Exemys logo is a registered trademark of Exemys LLC. All other trademarks mentioned in this document are the property of their respective owners.