

INPUTS & OUTPUTS CONFIGURATION OF EXEMYS DEVICES

Introduction

Many Exemys devices include Digital Inputs and Outputs. This document applies to you if you need to configure I/Os or if you want to know how I/O work.

Power Supply

In order to understand I/O capabilities, you must learn how to power your Exemys device. Either a DC (range 9-30 Vdc) or AC (9-26 Vac) power supply can be used. As a result, Exemys devices have no polarity, since an internal rectifier is always provided. GND connector is the common digital ground and is used when connecting digital inputs and outputs to external devices.

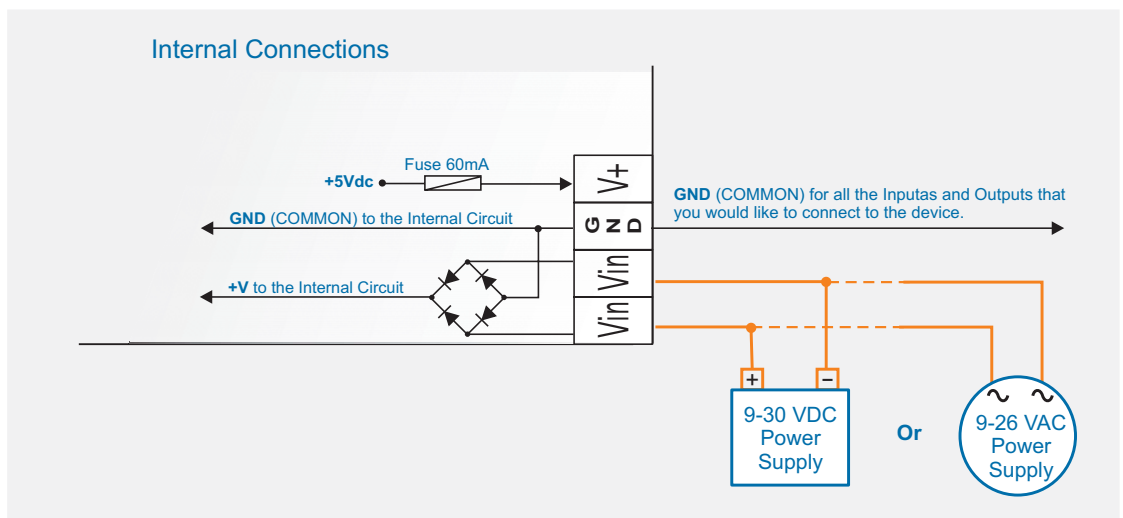

V+ connector is used to connect dry contact type digital inputs. It can source up to 60mA and it is fuse-protected.

Digital Inputs

Digital inputs are based on transistors configured in a *Sinking mode*. Transistors are active when a continuous voltage in the range 3.5 - 28VDC are applied to the inputs. This voltage may be provided by any external field device, either working in a *PNP Sourcing mode* or with dry contact devices, as shown in the pictures below.

Inputs connected to external field devices (PLC, sensor)

In this case, any external field device can activate an input with a continuous voltage, VDC.

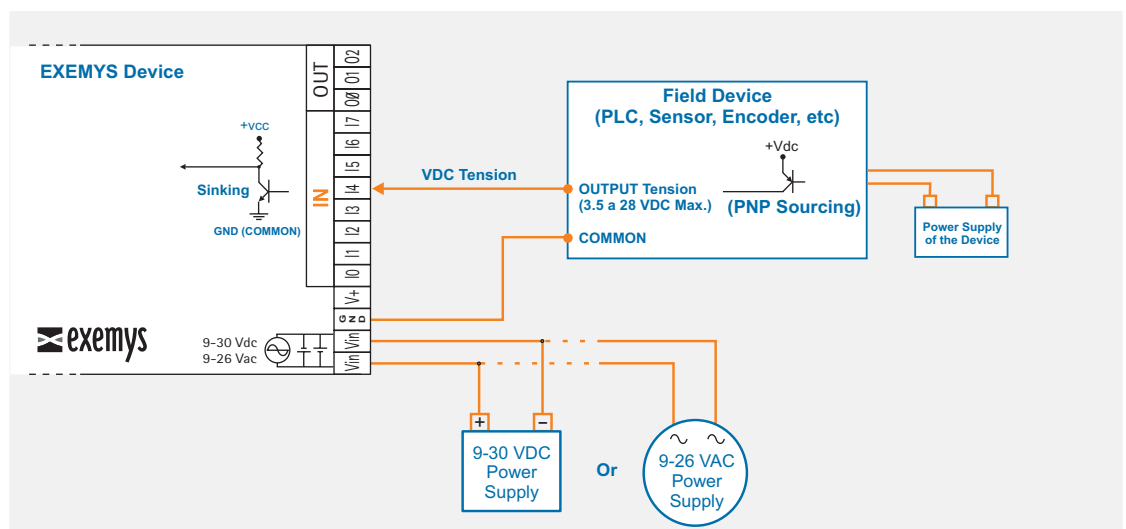

Inputs connected to dry contacts.

Inputs can be activated by dry contacts such as keys, relay outputs, opening sensors. There are several ways to connect dry contacts, depending on the power supply you use. Bellow, you will find all possible combinations:

- A) Dry contact input whose power supply is independent to that used by the Exemys' power supply.
- B) Dry contact input whose power supply is the same to that used by the Exemys' power supply.
- C) Dry contact input powered with the V+ connector provided with your Exemys device.

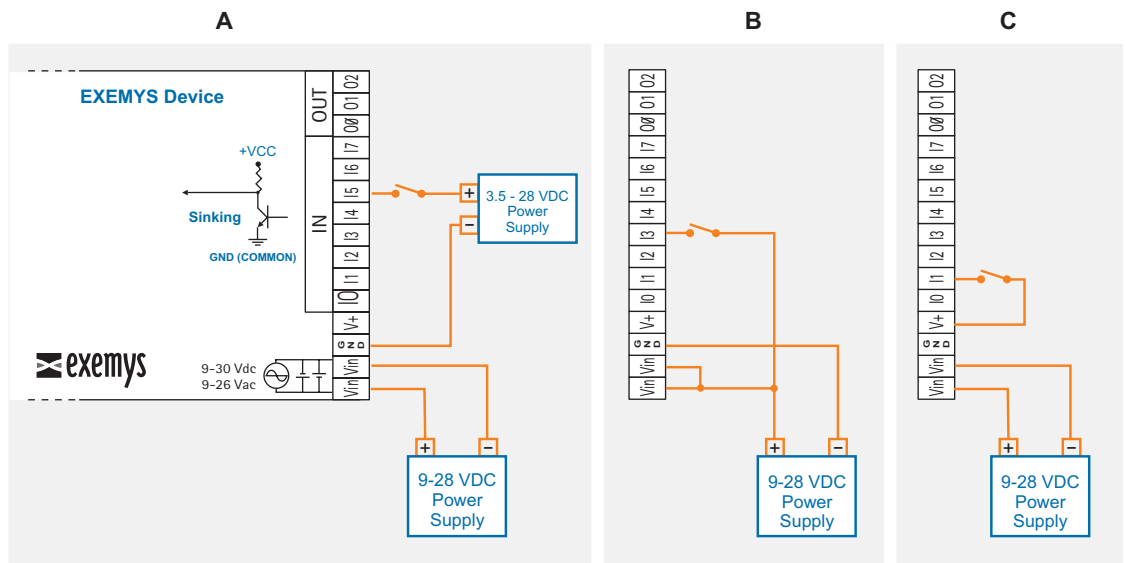

Digital Outputs

Digital outputs are transistor based, designed as a *NPN Sourcing* (open collector). Thus, when active, they are electrically tied to GND. Any load connected to an output should be powered in the range 3 - 45 Vdc. The schemes below depict the following cases.

- A) Output connected to a load whose power supply is different to that used to power your Exemys device.
- B) Output connected to a load whose power supply is the same to that used to power your Exemys device.

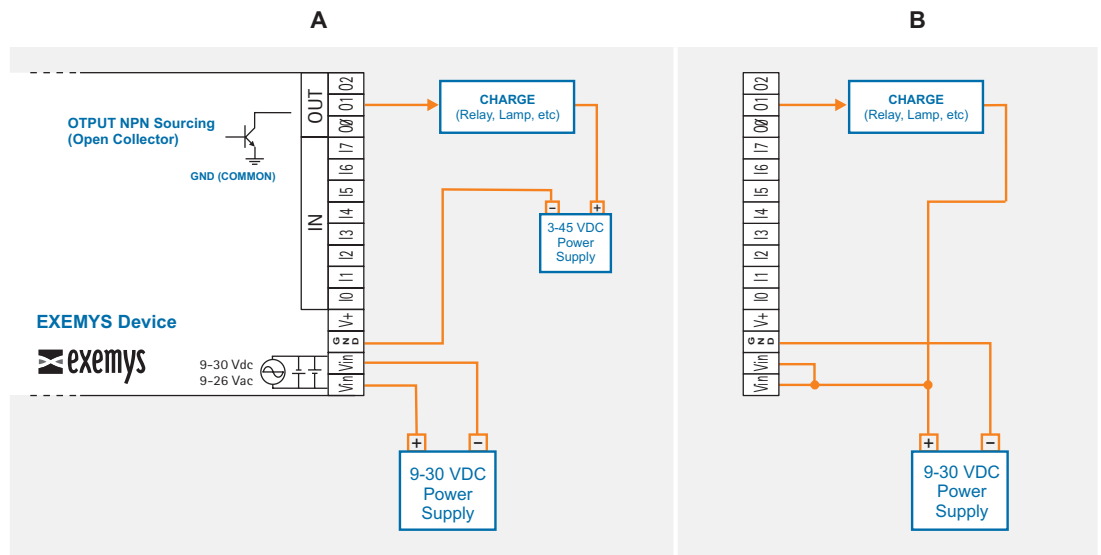

Technical Specifications

DIGITAL INPUTS	
Input Type	Sinking. Allow sensors and <i>PNP sourcing</i> devices.
Operating Voltage range	3.5 - 28 Volts DC
Input Current	1 - 11mA

DIGITAL OUTPUTS	
Output Type	<i>NPN Sourcing</i> (open collector)
Allowed Loading Voltage	3 - 45 Volts DC
Max. Output Current	130mA per output.

For technical support please contact:
support@exemys.com

For sales please contact:
sales@exemys.com

www.exemys.com